

# **Door Hardware – Maintenance & Replacement**

**Jacky Sinclair DipGAI, FIAI, RAI**  
*GAI Technical Consultant*

# Presentation Overview

- ✓ Checking what's fitted
- ✓ Replacing faulty items
- ✓ Where to get help
- ✓ Who to get it from

# Checking what's fitted

## Fire doors – do they close?



- If a fire/smoke door is not fully closed, it won't hold back any fire or smoke. Gaps get exploited.

- If a non-fire door is fully closed, it will give some protection for a short period



**Conclusion** – the difference between almost closed and fully closed is

**CRITICAL**

## Fire doors – do they close?



### Lubricate latch bolt

- Metal dust builds up on the latch face and the strike tongue, creating friction. Wipe it off with a little light machine oil

### Check that bolts align with their slots in the strike plate or keep

### Check angle of strike plate is correct

- If tongue is not pre-formed, use a mallet or hammer to bend it, creating a slope



# Checking what's fitted



This digital lock has been retro-fitted on a steel fire door and frame. There are issues!

- Where's the evidence that this door has been fire-tested with such a lock?
- Is there any fire test evidence for the lock?
- This type of latch shape is not suited to a square steel frame
- The door will only close if pulled from the secure side. (Location – on 5 floors of a block of flats, providing access to the escape stairs.)

*(Photo courtesy of Arnold Tarling)*

# Checking what's fitted

## Fire doors – do they close?

### ❑ Check hinge fixings

- Tighten as necessary, and replace any missing fixings with new (on timber, preferably No. 8 min. 30 mm long wood screws). A good fixing holds better in the cold state, and in fire.

### ❑ Check for wear at knuckles

- If door has dropped, replace all 3 hinges with better quality butts of same height and width
- Consider self-lubricating, long-life bearings or washers, rather than surfaces which need oiling. You will get what you pay for.

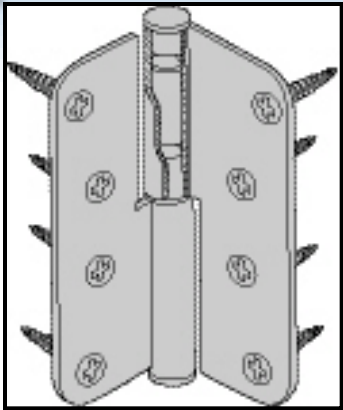

## Fire doors – do they close?



### ❑ Check hinge pins

- If rising out of knuckle, raise nose of door before knocking back in
- highly likely to recur, as it is a sign of hinge under-specified for door weight/duty.

### ❑ Lubricate hinges as required

- Any black dust on the knuckle is from ground metal – sign of wear and dry-running
- black gunge oozing from ball race bearings – bearing likely to collapse sooner or later



# Checking what's fitted



This broken rising butt on a fire door was “mended”, after being identified during an inspection, but it soon gave way again.

(Location – block of flats, door on to escape stairs.)

*Photo courtesy of Arnold Tarling)*

## Fire doors – do they close?

### ❑ Adjust the door closer for

- Closing speed (controlled closing) [C]
- Latching speed (final nudge home) [D]
- Backcheck (braking effect around 70° of opening) [B] - *option, not standard*
- Delayed action (creeping effect around 100° - 70° closing) [B] - *option, **delay < 25 secs** -BS EN 1154*
- Strength (adjustable power) [X] - *option*

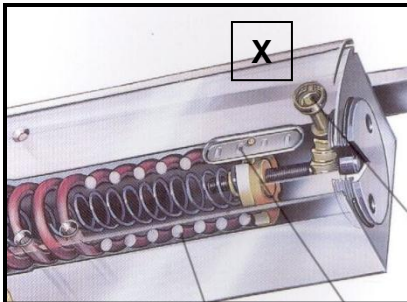
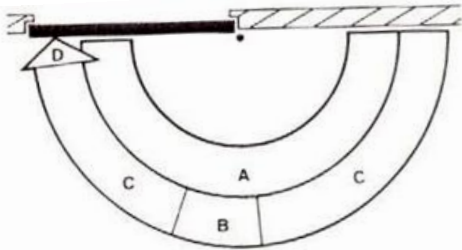

## Fire doors – do they close?

❑ Check the door closer for

➤ Arm assembly secure both ends

➤ Arm geometry correct

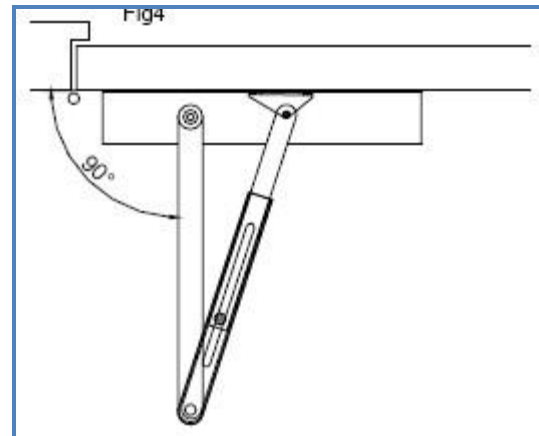
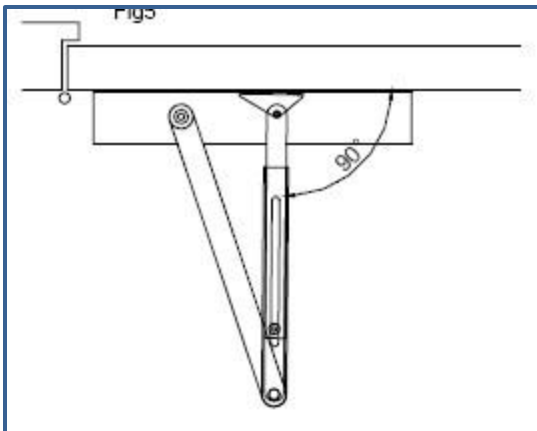

Wrong geometry changes the closer's action, and negates any performance certification and the CE mark. Check with the fixing instructions.

## Fire doors – do they close?

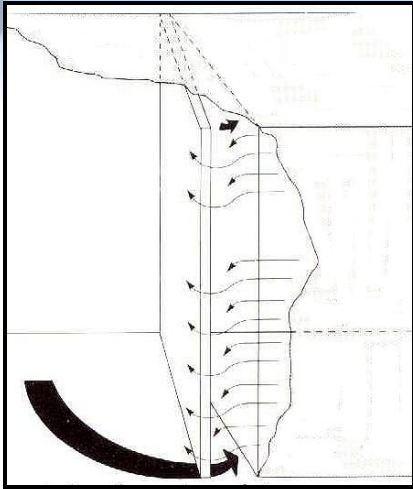

Does the door close fully from ANY angle? (Approved Doc B)

- Fully open (maximum angle)
- Latch resting against strike or
- Any edge seals starting to contact both door and frame (too much friction?)
- Is air pressure preventing closing? (small, air-tight rooms or lobbies)
- Are differential air pressures present? (pressured stairwell?)
- Do other open/closed windows and doors affect full closing?

# Checking what's fitted

## Fire doors – can they be opened?

- ❑ Check that the furniture (levers, knobs, pull handles) is securely fixed and operating correctly.

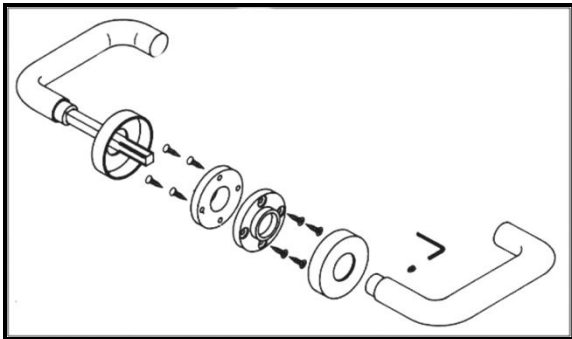
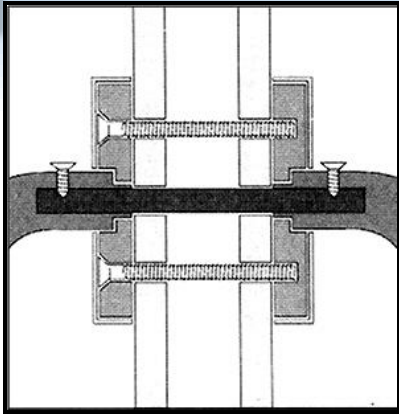

Thru' bolts, and spindles fixed into operating furniture (above left), are much more durable for commercial and frequent use than simple screw fixings (below left) and “floating” spindles. If you need to escape through the door, the handle must stay on the door when you grab it.

# Checking what's fitted

## Escape doors – do they open?

On emergency escape doors

(trained traffic / >60 occupants)

Is only ONE hand movement needed to release all bolts? (ADB)

➤ By turning a lever, or

➤ Pressing a push pad/pulling a pull pad

Other devices need very careful risk assessment

Does the door open easily?

➤ Inward or outward opening is allowed



# Checking what's fitted

## Escape doors – do they open?

On emergency escape doors

(trained traffic / >60 occupants)

### Is signage present and correct?

➤ BS EN 179 requires signage for how to operate the escape device

➤ BS 5499 (BS ISO 7010) requires escape route signs to be same type throughout premises: either EC or BS.

### Other ironmongery checks as for fire doors

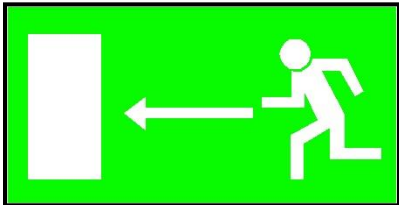

## Escape doors – do they open?

On panic escape doors (public access / <60 occupants)

- Does body pressure alone release the door, anywhere along its width?
- Does the door open easily?
- Is signage present and correct?
- Other ironmongery checks as for fire doors



# Checking what's fitted

## Escape doors – do they open?

On panic escape doors (public access / <60 occupants)



If extra security is fitted, is it connected to the fire alarm, to give instant release in an emergency?

Is it in working order?

If there are extra bolts or plastic ties, what's their story in court?

**“one mechanism . . . readily operated  
. . . at all material times”**

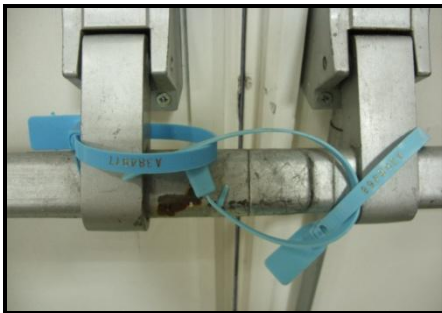

# Replacing faulty items

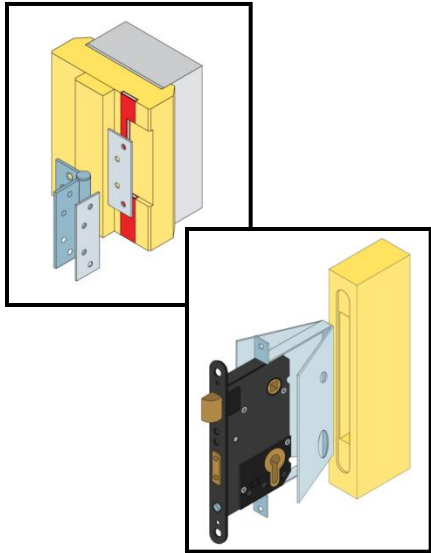

## If it's worn out or broken-

consider buying something better, not the same again!

- Check the fire test evidence
- Check if intumescent protection is needed
- Have it fitted by qualified fire door fitter (e.g. FIRAS approved)

## Finding reliable sources of information :

- Code of Practice: Hardware for fire and escape doors (published by DHF/GAI)

[www.firecode.org.uk](http://www.firecode.org.uk)

[www.gai.org.uk](http://www.gai.org.uk)

- PFPP website

[www.pfpp.org](http://www.pfpp.org)



# Who to get it from



- **Registered Architectural Ironmonger (RegAI)**

- Someone who has passed the GAI Diploma and also participates in annual CPD

- **GAI GuildMark member company**

- RIBA endorsed GAI scheme which includes QA and professional indemnity
- Company must employ a RegAI

- **GAI Full member company**

- Company must employ a DipGAI



- ✓ Check what's fitted and make sure it works properly
- ✓ Replace faulty items with better quality, where possible
- ✓ Get help from qualified professionals
- ✓ Buy products from reputable, knowledgeable companies
- ✓ Have products fitted by trained fire door fitters
- ✓ Keep checking and maintaining performance.

***THANKYOU !***

**Jacky Sinclair** DipGAI, RAI, FIAI

Technical Consultant, Guild of Architectural Ironmongers